

# DICOM Conformance Statement

## Philips Pathology Scanner SGI 1.0



*- This page is left intentionally empty -*

## 1. DICOM Conformance Statement Overview

This document is the DICOM Conformance Statement for Philips Pathology Scanner Second Generation interoperable 1.0 (SGi). Philips Pathology Scanner SGI consists of following sub-systems:

Scanner

- Pathology Scanner SGS60
- Pathology Scanner SGS300

The Scanner sends the images of the scanned slides to a remote DICOM System (PACS).

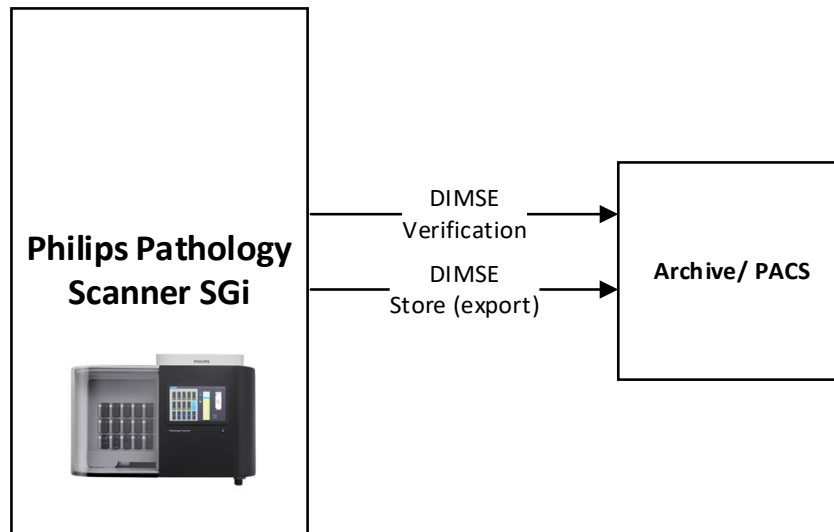

**Figure 1: Philips Pathology Scanner SGI**

**1.1. Content and Transfer**

Table 1-1 lists all Storage SOP Classes and the supported transfer mechanisms as well as the usage scenarios for those instances.

The "Transfer Syntax Set" column lists the sets of Transfer Syntaxes defined in Table 1-2 that are applicable to each SOP Class. The "DIMSE", "DICOM Web" and "Media Services" columns indicate the roles supported for each SOP Class.

The "Function" columns indicate how the instances are used by the system:

- **Create:** The system creates instances of the SOP Class. The type of the created SOP Class is indicated by one of the following abbreviations:
  - S: Standard SOP Class
  - SE: Standard Extended SOP Class
  - SP: Specialized SOP Class
  - P: Private SOP Class
- **Display:** The system displays the instances of the SOP Class to the user, either by displaying the SOP Instances natively or by applying instances of another suitable SOP Class to the image instances (e.g., a Presentation State or CAD SR).
- **Process:** The system processes the instances of the SOP Class to derive some further information that is made available to the user (e.g., a CAD processing algorithm, or a 3D Rendering).
- **Archive:** The system stores the instances of the SOP Class and makes them available again.

**Table 1-1: Storage SOP Classes**

SOP Classes		Transfer Syntax Set	DIMSE Services		DICOM Web Services		Media Services			Function				
			SCU	SCP	UA	OS	FSC	FSU	FSR	Create	Display	Process	Archive	
A.32.8. VL Whole Slide Microscopy Image IOD	1.2.840.10008.5.1.4.1.1.77.1.6	L	Yes	No	No	No	No	No	No	No	S	No	No	No

**Table 1-2: Supported Transfer Syntaxes**

Transfer Syntax Set	Transfer Syntax Name	Transfer Syntax UID	DICOM Web Service Bulkdata Media Type
Lossy Compressed Transfer Syntax Set (L)	JPEG Baseline (Process 1)	1.2.840.10008.1.2.4.50	N/A
	JPEG XL	1.2.840.10008.1.2.4.112	N/A

Only JPEG Baseline (Process 1) and JPEG XL transfer syntaxes are supported for VL Whole Slide Microscopy Image Storage. Due to the large file size of the DICOM IODs, the default Implicit VR Little-endian Transfer Syntax is not supported, only the Explicit VR Little Endian is used.

When JPEG XL is configured for export, a study consists of objects encoded in JPEG Baseline (Process 1) and JPEG XL transfer syntaxes, for a successful export of the study, the remote system must enable the support of both transfer syntaxes.

**1.1.1. Structured Reporting Root Template IDs**

Not applicable, not supported by product.

**1.2. DIMSE Services**

**1.2.1. Verification**

Table below lists support for the Verification SOP Class.

**Table 1-4: Verification SOP Class**

SOP Classes		Transfer Syntax		SCU	SCP
Verification	1.2.840.10008.1.1	Implicit VR Little Endian	1.2.840.10008.1.2	Yes	No
		Explicit VR Little Endian	1.2.840.10008.1.2.1	Yes	No

**1.2.2. Storage**

For details on supported Storage SOP Classes and transfer syntax see Section 1.1.

**1.2.3. Workflow Management – N/A**

Not applicable, not supported by product.

**1.2.4. Query/Retrieve – N/A**

Not applicable, not supported by product.

**1.2.5. Printing – N/A**

Not applicable, not supported by product.

**1.3. DICOM Web Services -N/A**

Not applicable, not supported by product.

**1.4. Media Services – N/A**

Not applicable, not supported by product.

**1.5. Real Time Video Service – N/A**

Not applicable, not supported by product.

**1.6. De-identification Profiles – N/A**

Not applicable, not supported by product.

**1.7. Specific Character Sets**

**Table 1-15: Supported Specific Character Sets**

Defined Term	IANA	Description
<b>Multi-Byte Character Sets without Code Extensions</b>		

Defined Term	IANA	Description
ISO_IR 192	ISO_IR 192	Unicode in UTF-8

## 2. Table of Contents

1.	DICOM Conformance Statement Overview .....	3
1.1.	Content and Transfer .....	4
1.1.1.	Structured Reporting Root Template IDs.....	5
1.2.	DIMSE Services .....	5
1.2.1.	Verification.....	5
1.2.2.	Storage.....	5
1.2.3.	Workflow Management – N/A.....	5
1.2.4.	Query/Retrieve – N/A.....	5
1.2.5.	Printing – N/A .....	5
1.3.	DICOM Web Services -N/A .....	5
1.4.	Media Services – N/A .....	5
1.5.	Real Time Video Service – N/A .....	5
1.6.	De-identification Profiles – N/A.....	5
1.7.	Specific Character Sets .....	5
2.	Table of Contents.....	7
3.	Introduction .....	9
3.1.	Revision History.....	9
3.2.	Audience.....	9
3.3.	Remarks.....	9
3.4.	Terms and Definitions .....	10
3.5.	Abbreviations .....	12
3.6.	References.....	12
4.	Implementation Model.....	13
4.1.	Application Entities and Data Flow.....	13
4.1.1.	Functional Definition of SGI AE.....	13
5.	Service and Interoperability Description .....	13
5.1.	Mapping of Services to Application Entities.....	13
5.2.	Supported DIMSE Services .....	14
5.2.1.	Verification Service .....	14
5.2.2.	Storage Service .....	15
5.2.3.	Basic Worklist Management Service – N/A .....	15
5.2.4.	Modality Performed Procedure Step Service -N/A.....	15
5.2.5.	Unified Worklist and Procedure Step Service – N/A.....	15
5.2.6.	Instance Availability Notification Service – N/A.....	15
5.2.7.	Storage Commitment Service – N/A.....	15
5.2.8.	Query/Retrieve Service Class – N/A.....	16
5.2.9.	Print Management Service -N/A.....	16
5.3.	Supported DICOM Web Services -N/A .....	16
5.4.	Media Service – N/A.....	16
5.5.	Real Time Video Service -N/A.....	16
6.	Configuration .....	16
6.1.	General Configuration Parameters.....	16
6.2.	Configuration of DIMSE Services .....	17
6.2.1.	Verification Service Configuration .....	17
6.2.2.	Storage Service Configuration .....	18
7.	Network and Media Communication Details.....	19
7.1.	General.....	19
7.1.1.	General Association Parameters.....	19
7.2.	Specifications.....	20
7.2.1.	SGI Application Entity .....	20
7.3.	Status Codes.....	21
7.3.1.	General AE Communication and Failure Behavior and Handling.....	22
7.3.2.	DIMSE Services.....	22

- 7.3.3. DICOM Web Services -N/A..... 24
- 8. Security ..... 24
  - 8.1. Introduction..... 24
  - 8.2. External Network Requirements ..... 24
  - 8.3. TCP Port Configuration ..... 25
  - 8.4. DICOM Security Profiles Support ..... 25
    - 8.4.1. Secure Use and User Identity Profiles – N/A ..... 25
    - 8.4.2. Secure Transport Connection Profiles ..... 25
    - 8.4.3. Media Storage Security Profiles -N/A ..... 25
    - 8.4.4. Attribute Confidentiality Profiles -N/A ..... 25
    - 8.4.5. Digital Signature Profiles -N/A ..... 25
    - 8.4.6. Additional DICOM Security Profiles -N/A..... 25
  - 8.5. User Identity Negotiation Support -N/A..... 25
  - 8.6. Web Services Security Features -N/A..... 25
- A. Information Object Definitions (IODs) ..... 26
  - A.1 Information Shared Across Multiple IODs – N/A ..... 26
  - A.2 VL Whole Slide Microscopy Image IOD ..... 27
    - A.2.1 VL Whole Slide Microscopy Image IOD - Specific Modules ..... 27
    - A.2.2 VL Whole Slide Microscopy Image IOD - Functional Group Macros ..... 37
    - A.2.3 VL Whole Slide Microscopy Image IOD - Private Modules -N/A ..... 39
    - A.2.4 VL Whole Slide Microscopy Image IOD - Coded Values ..... 39
- B. Structured Report Content Encoding – N/A ..... 41
- C. Security Details ..... 41
  - C.1 External Network Requirement Details ..... 41
    - C.1.1 Basic Time Synchronization ..... 41
    - C.1.2 Basic Network Address Management ..... 41
  - C.2 DICOM Security Profile Details ..... 41
    - C.2.1 Online Electronic Storage Secure Use – N/A ..... 41
    - C.2.2 Audit Trail Messages -N/A ..... 41
    - C.2.3 Audit Trail Message Transmission Profile - SYSLOG – TLS -N/A ..... 41
    - C.2.4 Audit Trail Message Transmission Profile - SYSLOG – UDP -N/A..... 41
    - C.2.5 Secure Transport Connection Details ..... 41
    - C.2.6 Attribute Confidentiality Details -N/A ..... 43
    - C.2.7 Digital Signature Details – N/A ..... 43
    - C.2.8 Additional DICOM Security Profile Details – N/A ..... 43
- D. Mapping of Attributes -N/A ..... 43
- E. Code Set Usage ..... 43

### 3. Introduction

The introduction specifies product and relevant disclaimers as well as any general information that the vendor feels is appropriate.

#### 3.1. Revision History

The revision history provides dates and differences of the different releases.

**Table 1: Revision History**

Document Version	Date of Issue	Description of change
01	06-Mar-2026	Initial version for Philips Pathology Scanner SGi 1.0

#### 3.2. Audience

This document is intended for the audience listed below. It is assumed that the reader has a working knowledge of the DICOM Standard.

The document structure was designed for easier access to relevant information for different user groups:

- Clinical Users, who want to get an overview of the implemented interoperability features of the system can see Section 4 Implementation Model.
- Personnel involved in Sales can use the information in Section 1 to assess the compatibility between different systems involved in a sales situation.
- System Integrators can use information in Section 6 during system installation and also information from Section 5 Service and Interoperability Description for details regarding the implemented services.
- Field Service Engineers can use the details from Section 5 Service and Interoperability Description and from Section 7 Network and Media Communication Details for troubleshooting.
- Hospital IT staff focusing on security can use the details provided in Section 8 Security regarding implemented Security features.
- Research Personnel may be interested in using information provided in Appendix A Information Object Definitions (IODs).

#### 3.3. Remarks

The scope of this DICOM Conformance Statement is to facilitate integration between Philips Pathology Scanner SGi and other DICOM products. The Conformance Statement should be read and understood in conjunction with the DICOM Standard. DICOM by itself does not guarantee interoperability.

- The Conformance Statement does, however, facilitate a first-level comparison for interoperability between different applications supporting compatible DICOM functionality.
- This Conformance Statement should not replace validation with other DICOM equipment to ensure proper exchange of intended information. In fact, it is the user's responsibility to perform the following validation activities:

- The comparison of Conformance Statements from Philips Pathology Scanner SGI and other DICOM conformant equipment is the first step towards assessing interconnectivity and interoperability between those systems.
- Test procedures should be defined and executed to validate the required level of interoperability with specific DICOM conformant equipment, as established by the healthcare facility.

**3.4. Terms and Definitions**

The following list includes DICOM Terms, that are used throughout this Conformance Statement:

**Table 3-2: Terms and Definitions**

Abstract Syntax	The information agreed to be exchanged between applications, generally equivalent to a Service/Object Pair (SOP) Class. Examples: Verification SOP Class, Modality Worklist Information Model Find SOP Class, Computed Radiography Image Storage SOP Class.
Application Entity (AE)	A representation of the external behavior of an application process in terms of DICOM Network Services, Web Services and/or media exchange capabilities implemented in one or more roles. A single device may have multiple Application Entities.
Application Entity Title (AET)	The externally known name of an Application Entity, used to identify a DICOM application to other DICOM applications on the network.
Application Context	The specification of the type of communication used between Application Entities. Example: DICOM network protocol.
Association	A network communication channel set up between Application Entities.
Attribute	A unit of information in an Information Object Definition; a Data Element identified by a tag. The information may be a complex data structure (Sequence), itself composed of lower-level data elements. Examples: Patient ID (0010,0020), Accession Number (0008,0050), Photometric Interpretation (0028,0004), Procedure Code Sequence (0008,1032).
Data Element	A unit of information as defined by a single entry in the data dictionary. An encoded Information Object Definition (IOD) Attribute that is composed of, at a minimum, three fields: a Data Element Tag, a Value Length, and a Value Field. For some specific Transfer Syntaxes, a Data Element also contains a VR Field where the Value Representation of that Data Element is specified explicitly
Information Object Definition (IOD)	The specified set of Attributes that comprise a type of data object; does not represent a specific instance of the data object, but rather a class of similar data objects that have the same properties. Examples: MR Image IOD, CT Image IOD, Print Job IOD. The Attributes within an IOD may be specified as Mandatory (Type 1), Required but possibly unknown (Type 2), or Optional (Type 3), and there may be conditions associated with the use of an Attribute (Types 1C and 2C).
Media Application Profile	The specification of DICOM information objects and encoding exchanged on removable media (e.g., CDs).

Module	A set of Attributes within an Information Object Definition that are logically related to each other. Example: Patient Module includes Patient's Name, Patient ID, Patient' Birth Date, and Patient's Sex.
Negotiation	First phase of Association establishment that allows Application Entities to agree on the types of data to be exchanged and how that data will be encoded.
Origin Server	Refers to the program that can originate authoritative responses to HTTP requests for a given Target Resource. The term "server" refers to any implementation that receives a web service request message from a user agent.
Presentation Context	The set of DICOM Network Services used over an Association, as negotiated between Application Entities; includes Abstract Syntaxes and Transfer Syntaxes.
Private SOP Class	A SOP Class that is not defined in the DICOM Standard but is published in an implementation's Conformance Statement.
Protocol Data Unit (PDU)	A packet (piece) of a DICOM message sent across the network. Devices must specify the maximum size packet they can receive for DICOM messages.
RWA	Real-world activities; It is used to define the real-world objects or events that DICOM objects represent
Security Profile	A set of mechanisms, such as encryption, user authentication, or digital signatures, used by an Application Entity to ensure confidentiality, integrity, and/or availability of exchanged DICOM data.
Service Class Provider (SCP)	Role of an Application Entity that provides a DICOM network service; typically, a server that performs operations requested by another Application Entity (Service Class User). Examples: Picture Archiving and Communication System (image storage SCP, and image query/retrieve SCP), Radiology Information System (modality worklist SCP).
Service Class User (SCU)	Role of an Application Entity that uses a DICOM Network Service; typically, a client. Examples: imaging modality (image storage SCU, and modality worklist SCU), imaging workstation (image query/retrieve SCU).
Service/Object Pair Class (SOP Class)	The specification of the network or media transfer (service) of a particular type of data (object); the fundamental unit of a DICOM interoperability specification. Examples: Ultrasound Image Storage Service, Basic Grayscale Print Management.
Service/Object Pair Instance (SOP Instance)	An information object; a specific occurrence of information exchanged in a SOP Class. E.g., a specific X-ray image.
Specialized SOP Class	A SOP Class that is derived from the Standard that is specialized by additional type 1, 1C, 2, 2C, or 3 Attributes, by enumeration of specific permitted Values for Attributes, or by enumeration of specific permitted Templates. The additional Attributes may either be drawn from the Data Dictionary in PS3.6 or may be Private Attributes.
Standard SOP Class	A SOP Class defined in the Standard, and that is implemented and used without any modifications.

Standard Extended SOP Class	A SOP Class that is defined in the standard, and that is extended by additional type 3 Attributes. The additional Attributes may either be drawn from the DICOM Data Dictionary in PS3.6 or may be Private Attributes.
Tag	A 32-bit identifier for a Data Element, represented as a pair of four-digit hexadecimal numbers, the "group" and the "element". If the "group" number is odd, the tag is for a private (manufacturer-specific) data element. Examples: (0010,0020) [Patient ID], (07FE,0010) [Pixel Data], (0019,0210) [private data element].
Transfer Syntax	The encoding used for exchange of DICOM information objects and messages. Examples: JPEG compressed (images), Little Endian Explicit Value Representation.
TLS-Secured Port	TCP port on which an implementation accepts TLS connections to exchange DICOM information.
Unique Identifier (UID)	A globally unique "dotted decimal" string that identifies a specific object or a class of objects; an ISO-8824 Object Identifier. Examples: Study Instance UID, SOP Class UID, SOP Instance UID.
User Agent	A client in a network protocol used in communications within a client-server distributed computing system. In particular, the Hypertext Transfer Protocol (HTTP) identifies the client software originating the request, using a user-agent header, even when the client is not operated by a user.
Value Representation (VR)	The format type of an individual DICOM data element, such as text, an integer, a person's name, or a code. DICOM information objects can be transmitted with either explicit identification of the type of each data element (Explicit VR), or without explicit identification (Implicit VR) ; with Implicit VR, the receiving application must use a DICOM data dictionary to look up the format of each data element.

### 3.5. Abbreviations

Abbreviations that are used in this DICOM Conformance Statement are listed here.

ARTIM	Association Request/Reject/Release Timer
DCP	Digital and Computational Pathology
HIS	Hospital Information System
IMS	Image Management System
LIS	Laboratory Information System
SGi	Second Generation Interoperable

### 3.6. References

National Electrical Manufacturers Association (NEMA), Rosslyn, VA USA. *PS3 / ISO 12052 Digital Imaging and Communications in Medicine (DICOM) Standard*. <http://www.dicomstandard.org>.

## 4. Implementation Model

The implementation model consists of three sections:

- The application data flow diagram, specifying the relationship between the Application Entities and the "external world" or Real-World Activities,
- A functional description of each Application Entity, and
- The sequencing constraints among them.

### 4.1. Application Entities and Data Flow

The network and media interchange application model for the Philips Pathology Scanner SGi is shown below.

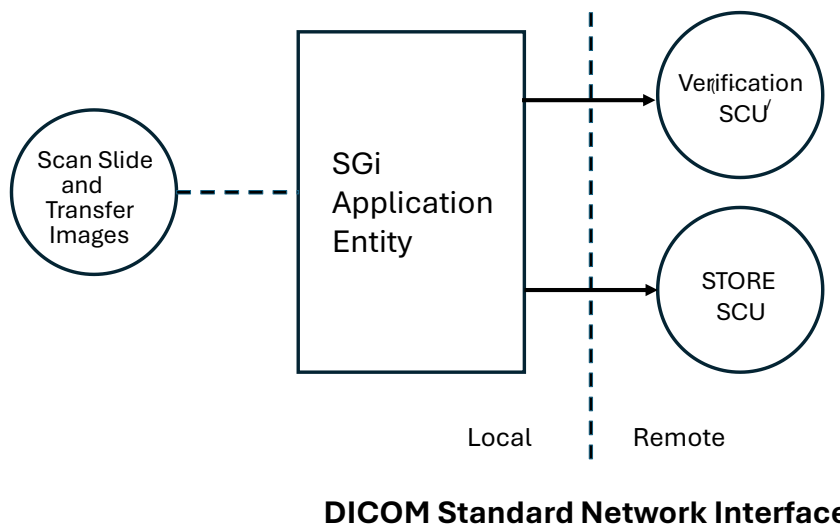

**Figure 2: Philips Pathology Scanner SGi AE Data Flow Diagram**

This section describes the organization of the supported Services into Application Entities based on the default configuration of the system. This may change based on the actual setup at the customer site. See Section 6 for details about the configurability of Services into AEs.

#### 4.1.1. Functional Definition of SGi AE

The Philips Pathology Scanner SGi digitizes pathology slides and transfers the acquired image to the PACS server.

## 5. Service and Interoperability Description

### 5.1. Mapping of Services to Application Entities

Table below provides an overview of the Application Entities and the Services supported by each AE.

**Table 5-1: Service to AE Mapping**

Application Entity	Supported Services	Role								
		DIMSE		DICOM Web		DICOM Media			Real-Time Video	
		SCU	SCP	Origin Server	User Agent	FSC	FSU	FSR	SCU	SCP
SGi AE	Storage	Yes	No	No	No	No	No	No	No	No
	Verification	Yes	No	No	No	No	No	No	No	No

**5.2. Supported DIMSE Services**

**5.2.1. Verification Service**

**5.2.1.1. SCU of the Verification SOP Class**

The figure below shows sequencing of RWA for Verification as SCU.

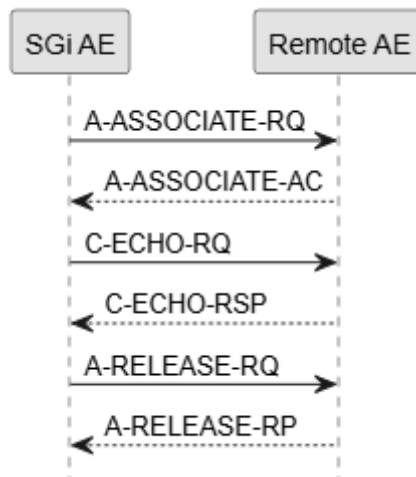

**Figure 3: Real World Activity – Verification as SCU**

As a Service Class User of the Verification Service Class, the Philips Pathology Scanner SGI uses the C-ECHO-RQ message to request DICOM verification of the connection to a remote SCP. Only after successful C-ECHO-RSP is received, the association is released. If a timeout occurs or the C-ECHO-RSP indicates anything other than Success, the association is aborted.

**5.2.1.2. SCP of the Verification SOP Class – N/A**

Not applicable, not supported by product.

**5.2.2. Storage Service**

**5.2.2.1. SCU of the Storage SOP Classes**

The figure below shows sequencing of RWA for Storage as SCU.

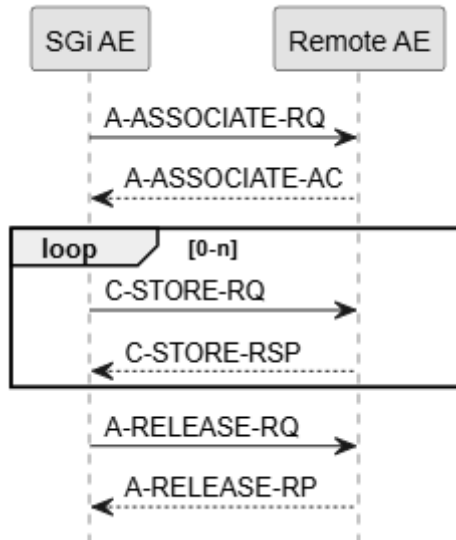

**Figure 4: Real World Activity – Storage as SCU**

As a Service Class User of the Storage Service Class, the Philips Pathology Scanner SGI uses the C-STORE-RQ message to request storage of DICOM objects by a remote SCP. See Section 1.1 Content and Transfer in the Overview for the list of supported SOP Classes.

For details regarding the content of SOP Instances that are created by the system, see Appendix A, which describes the underlying IOD of the supported SOP Classes.

The completion of a slide scan automatically triggers the storage requests.

**5.2.2.2. SCP of the Storage SOP Classes – N/A**

Not applicable, not supported by product.

**5.2.3. Basic Worklist Management Service – N/A**

Not applicable, not supported by product.

**5.2.4. Modality Performed Procedure Step Service -N/A**

Not applicable, not supported by product.

**5.2.5. Unified Worklist and Procedure Step Service – N/A**

Not applicable, not supported by product.

**5.2.6. Instance Availability Notification Service – N/A**

Not applicable, not supported by product.

**5.2.7. Storage Commitment Service – N/A**

Not applicable, not supported by product.

**5.2.8. Query/Retrieve Service Class – N/A**

Not applicable, not supported by product.

**5.2.9. Print Management Service -N/A**

Not applicable, not supported by product.

**5.3. Supported DICOM Web Services -N/A**

Not applicable, not supported by product.

**5.4. Media Service – N/A**

Not applicable, not supported by product.

**5.5. Real Time Video Service -N/A**

Not applicable, not supported by product.

**6. Configuration**

Throughout all subsections the following Values can be used in the "Configurable" column:

- USER: The parameter is configurable by the user.
- SERVICE: The parameter is configurable by service personnel.
- FIXED: The parameter is not configurable (it has a fixed Value). The Value is required for the configuration of the remote system.
- N/A: The parameter is not applicable for the local or the remote system.

**6.1. General Configuration Parameters**

Table 6-1 lists general configuration parameters applicable across all supported DICOM Services.

**Table 6-1: General Configuration Parameters**

Parameter	Configurable	Default Value	Comments
<b>General Parameters</b>			
Timeout waiting for acceptance or rejection Response to an Association Open Request. (Application-Level timeout)	FIXED	30 sec	
Timeout waiting for a response to an Association Release Request (Application Level Timeout)	FIXED	30 sec	
<b>TCP/IP Settings</b>			
TCP/IP Send Buffer	FIXED	16 KB	Min: 4KB, Max: 4MB
TCP/IP Receive Buffer	FIXED	128 KB	Min 4KB, Max: 6MB

Parameter	Configurable	Default Value	Comments
<b>DICOM Services Parameters</b>			
Specific Character Set	FIXED	ISO_IR 192	

## 6.2. Configuration of DIMSE Services

The tables in the following subsections show the configuration parameters required for DIMSE Services.

In order to identify whether Philips Pathology Scanner SGI is an SCU, the following applies:

- SCP: The (Secured) Local Called AET and Remote Calling AET parameters are present.
- SCU: The (Secured) Local Calling AET and Remote Called AET parameters are present.

### 6.2.1. Verification Service Configuration

Table 6-5 lists Verification Service configuration parameters:

**Table 6-5: Verification Service Parameters**

<b>Local Configuration Parameters – Verification Service</b>			
Parameter	Configurable	Default Value	Comments
Calling AE Title (SCU)	SERVICE		
<b>Remote Configuration Parameters – Verification Service</b>			
Host	SERVICE		
Port	SERVICE	2762	
Security Level	SERVICE		Values: None, BCP-195, Modified-BCP-195.
Client certificate + PassPhrase	SERVICE		If SCP requires authentication.
Called AE Title (SCP)	SERVICE		
General DIMSE level time-out values (ECHO)	FIXED	WRITE_TIMEOUT: 30 sec WAIT_FOR_RESPONSE_TIMEOUT: 30 sec	

**6.2.2. Storage Service Configuration**

Table 6-6 lists Storage Service configuration parameters:

**Table 6-6: Storage Service Parameters**

<b>Local Configuration Parameters - Storage Service</b>			
<b>Parameter</b>	<b>Configurable</b>	<b>Default Value</b>	<b>Comments</b>
Calling AE Title (SCU)	SERVICE		
Transfer syntax	SERVICE		
<b>Remote Configuration Parameters - Storage Service</b>			
Host	SERVICE		
Port	SERVICE	2762	
Security Level	SERVICE		Values: None, BCP-195, Modified-BCP-195.
Client certificate + Passphrase	SERVICE		If SCP requires authentication.
Called AE Title (SCP)	SERVICE		
General DIMSE level time-out values (Storage)	FIXED	WRITE_TIMEOUT: 30 sec WAIT_FOR_RESPONSE_TIMEOUT: 30 sec	

## 7. Network and Media Communication Details

### 7.1. General

The cross interaction between the AEs is depicted in the diagrams below.

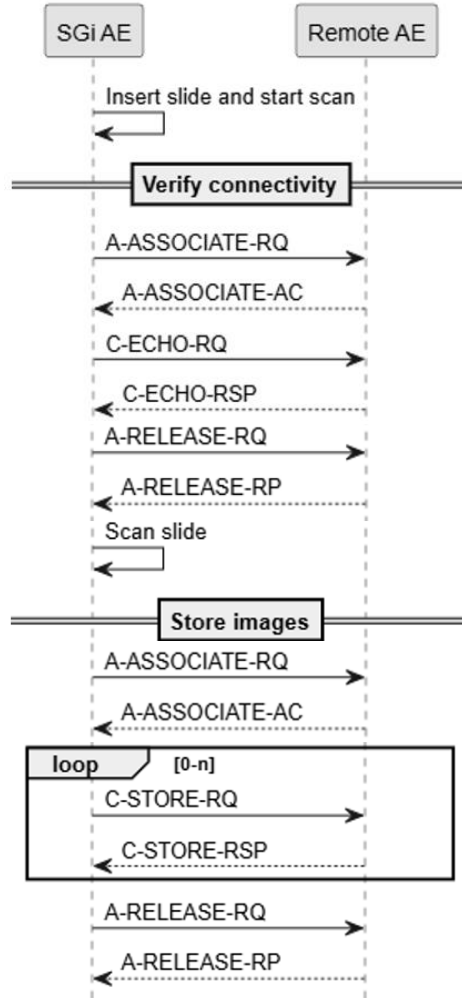

Figure 5: Real-World Activity and Cross AE interaction

#### 7.1.1. General Association Parameters

As the product implements a single application entity the association parameters are specified in Section 7.2.1.3 lists Association parameters applicable to the AE on the system.

7.2. Specifications

7.2.1. SGi Application Entity

7.2.1.1. Sequencing of Real-World Activities for Verification

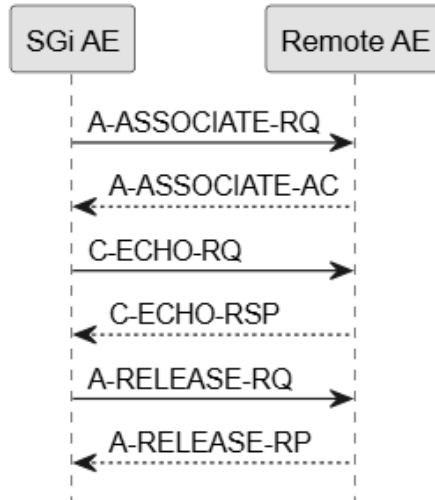

Figure 6: Sequencing of Real-World Activities for SGi AE

7.2.1.2. Sequencing of Real-World Activities for Image Export

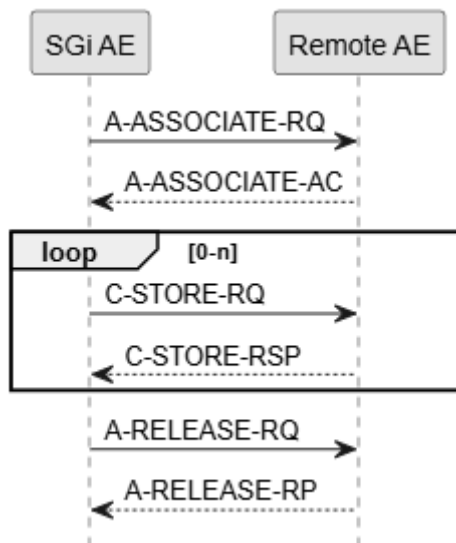

Figure 7: Sequencing of Real-World Activities for SGi AE

7.2.1.3. Association Parameters of SGi AE

Table below lists Association parameters applicable to SGi AE.

**Table 7-2: Association Parameters for SGI AE**

Service	Name	Value
Networking Services	Application Context Name	1.2.840.10008.3.1.1.1
	Implementation Class UID	1.3.46.670589.65.1
	Implementation Version Name	SGS1
	Maximum PDU Length	Default: 64 kB
	ARTIM Timeout	Default: 30s
	Maximum number of simultaneous Associations as Association Initiator	3
	Maximum number of outstanding asynchronous Transactions	0

The implementation does not support asynchronous transactions.

**7.2.1.4. Association Initiation**

This section details the Association policies of the Application Entity when it is initiating an Association.

**7.2.1.4.1. Real-World Activity - Image Export**

SGi AE stores images without Storage Commitment. The sequence is triggered by inserting a rack and closing the SGS store door.

For each slide, the SGI AE first checks connectivity to the Remote AE by requesting an association, sending a verification request, and then releasing the association. If the check is successful, the slide scan begins. On completion of the slide scan, the SGI AE will request an association with the Remote AE for the applicable Storage SOP classes. After accepting the association, the SGI AE will send a store request for each DICOM file, wait for response, and then release the association. The store outcome may be inspected on the UI.

**7.2.1.4.2. Real-World Activity – Verification**

SGi AE requests verification to a remote system using the C-ECHO command.

**7.2.1.5. Association Acceptance - N/A**

Not applicable, not supported by the product.

**7.3. Status Codes**

The following sections describe the Status Codes supported by the system for each implemented service as well as the reason for issuing specific Status codes or the associated behavior when receiving it.

**7.3.1. General AE Communication and Failure Behavior and Handling**

**7.3.1.1. Communication Failure Behavior as Association Initiator**

Table below describes behavior of the AE if a communication failure occurs when it initiated an Association.

**Table 7-8: DICOM Communication Failure Behavior as Association Initiator**

<b>Failure</b>	<b>Failure Behavior</b>
Timeout	If no messages after the Association request are received and it times out, the Association is marked as failed. The failure is reported to the user.
Association aborted	If an ABORT happens during the Association, the Association is marked as failed. The failure is reported to the user.
Network Disconnect	If the network is disconnected during Association, the Association is marked as failed. The failure is reported to the user.

**7.3.1.2. Communication Failure Handling as Association Acceptor -N/A**

Not applicable, not supported by the product.

**7.3.2. DIMSE Services**

**7.3.2.1. Verification Service**

**7.3.2.1.1. SCU of the Verification SOP Class - C-ECHO**

Table below lists the Status Codes that the SCU of the Verification SOP Class supports for the C-ECHO message and defines the application behavior when encountering the listed Status Codes.

**Table 7-9: Status Codes C-ECHO for the Verification SOP Class - SCU**

<b>Service Status</b>	<b>Further Meaning</b>	<b>Status Code</b>	<b>Behavior</b>
Success	Success	0000	Scanner is capable of scanning slides.
-	Other status codes	anything else	Scanner pauses slide scanning until successful C-ECHO.

**7.3.2.1.2. SCP of the Verification SOP Class - C-ECHO – N/A**

Not applicable, not supported by the product.

**7.3.2.2. Storage Service**

**7.3.2.2.1. SCU of the Storage SOP Classes - C-STORE**

Table below lists the Status Codes that the SCU of the Storage SOP Class supports for the C-STORE message and defines the application behavior when encountering the listed Status Codes.

**Table 7-10: Status Codes C-STORE for the Storage SOP Classes - SCU**

<b>Service Status</b>	<b>Further Meaning</b>	<b>Status Code</b>	<b>Behavior</b>
Success	Success	0000	Slide scan marked successful
Warning	Attribute List warning	0107	Association aborted, slide scan marked as failed.
	Coercion of Data Elements	B000	Association aborted, slide scan marked as failed.
	Data Set does not match SOP Class	B007	Association aborted, slide scan marked as failed.
	Elements Discarded	B006	Association aborted, slide scan marked as failed.
Failure	Invalid SOP Instance	0117	Association aborted, slide scan marked as failed.
	Refused: SOP Class not supported	0122	Association aborted, slide scan marked as failed.
	Refused: Not authorized	0124	Association aborted, slide scan marked as failed.
	Duplicate Invocation	0210	Association aborted, slide scan marked as failed.
	Unrecognized Operation	0211	Association aborted, slide scan marked as failed.
	Mistyped Argument	0212	Association aborted, slide scan marked as failed.
	Refused: Out of resources	A700-A7FF	Association aborted, slide scan marked as failed.
	Error: Data Set does not match SOP Class	A900-A9FF	Association aborted, slide scan marked as failed.
	Error: Cannot understand	C000-CFFF	Association aborted, slide scan marked as failed.
-	Other status codes	anything else	Association aborted, slide scan marked as failed.

**7.3.2.2.2. SCP of the Storage SOP Classes - C-STORE – N/A**

Not applicable, not supported by the product.

**7.3.2.3. Basic Worklist Management Service -N/A**

Not applicable, not supported by the product.

**7.3.2.4. Modality Performed Procedure Step Service -N/A**

Not applicable, not supported by the product.

**7.3.2.5. Unified Worklist und Procedure Step Service -N/A**

Not applicable, not supported by the product.

**7.3.2.6. Instance Availability Notification Service -N/A**

Not applicable, not supported by the product.

**7.3.2.7. Storage Commitment Service -N/A**

Not applicable, not supported by the product.

**7.3.2.8. Query/Retrieve Service – N/A**

Not applicable, not supported by the product.

**7.3.2.9. Print Management Service – N/A**

Not applicable, not supported by the product.

**7.3.3. DICOM Web Services -N/A**

Not applicable, not supported by the product.

**8. Security**

**8.1. Introduction**

The security section describes security features implemented by this product. It includes descriptions of non-DICOM network protocols, information to configure firewalls and application whitelists, lists of supported DICOM security profiles as well as Web Security features. Additionally, secured media storage, VPN, etc. are also specified in this security section.

**8.2. External Network Requirements**

Table 8-1 describes additional non-DICOM network protocols that are used by Philips Pathology Scanner SGI.

**Table 8-1: External Network Requirements**

Profile	Actor	Transaction	Protocol Used	RFCs	Security Support	Reference
Basic Time Synchronization	NTP Client	Maintain Time	NTP	RFC5905	No	C.1.1
Basic Network Address Management	DHCP Client	Find and Use DHCP Server	DHCP	RFC2131; RFC2132	No	C.1.2
		Maintain Lease	DHCP	RFC2131; RFC2132	No	C.1.2
	DNS Client	Resolve Hostname	DNS	RFC1035; RFC2181	No	C.1.2
System and audit log	Syslog client	Transfer system log and audit log messages to external log server	syslog	RFC5425; RFC791	No	N/A
Anti-Malware	Anti-Malware client	Update anti malware definitions.	HTTP	RFC2616	No	N/A

Profile	Actor	Transaction	Protocol Used	RFCs	Security Support	Reference
Software Update	Software Update	Download updates of software on the scanner	HTTP	RFC2616; RFC791	No	N/A

**8.3. TCP Port Configuration**

See Section 6 Configuration for information on the usage of ports for DICOM and other protocols.

**8.4. DICOM Security Profiles Support**

**8.4.1. Secure Use and User Identity Profiles – N/A**

Not applicable, not supported by the product.

**8.4.2. Secure Transport Connection Profiles**

Table 8-3 describes the Secure Transport Connection Profiles supported by the product. Accepted cipher suites are described in the section listed in the "Reference" column.

**Table 8-3: Secure Transport Connection Profiles**

Profile	Secured AE	Sender	Receiver	Reference
BCP 195 RFC 8996, 9325 TLS Secure Transport Connection Profile	Yes	Yes	No	C.2.5
Modified BCP 195 RFC 8996, 9325 TLS Secure Transport Connection Profile	Yes	Yes	No	C.2.5

**8.4.3. Media Storage Security Profiles -N/A**

Not applicable, not supported by the product.

**8.4.4. Attribute Confidentiality Profiles -N/A**

Not applicable, not supported by the product.

**8.4.5. Digital Signature Profiles -N/A**

Not applicable, not supported by the product.

**8.4.6. Additional DICOM Security Profiles -N/A**

Not applicable, not supported by the product.

**8.5. User Identity Negotiation Support -N/A**

Not applicable, not supported by the product.

**8.6. Web Services Security Features -N/A**

Not applicable, not supported by the product.

## Annex

### A. Information Object Definitions (IODs)

This section describes all the SOP Instances natively created by Philips Pathology Scanner Second Generation interoperable 1.0 (SGi).

In the "Source" column, the following Values can be used:

- **FIXED:** The Value is pre-defined and cannot be modified.
- **GENERATED:** The Value is generated by the system.
- **CONFIGURATION:** The Value is copied from the system configuration.
- **MWL:** The Value is copied from a Modality Worklist entry.
- **QUERY:** The Value is determined by performing a query of any of the supported Query/Retrieve Services.
- **USER:** The Value is entered by the user.
- **SCANNED:** The Value is read from a barcode scanner or similar device.
- **EMPTY:** The Attribute is sent with a zero-length Value.
- **SRC\_INSTANCE:** The Value is copied from previously created/received SOP Instances.

The "Presence" columns reflect the usage of the Module, Functional Group Macro, Attributes, or Value in the Philips Pathology Scanner Second Generation interoperable 1.0 (SGi) Implementation and is not necessarily the same as defined in the DICOM Standard. For the "Presence" column the following Values can be used:

- **ALWAYS:** the module, functional group macro, Attributes or Value is always present.
- **CONDITIONAL:** the presence of the module, functional group macro, Attributes or Value is dependent on the condition. The conditions must be listed in the "Conditions" column.
- **SRC\_COPY:** The presence of the Attributes and Values depends on the availability of these in the source instances, which are used for copying this information.
- **EMPTY:** The Attribute is present but without a Value (zero length).

#### A.1 Information Shared Across Multiple IODs – N/A

Not applicable, as the product only creates a single IOD, specified in Section A.2.

**A.2 VL Whole Slide Microscopy Image IOD**

Table below defines the structure of VL Whole Slide Microscopy Image IOD

**Table A-2: VL Whole Slide Microscopy Image IOD**

IE	Module Name	Presence (Module)	Condition	Reference
<b>Patient</b>	Patient	ALWAYS		<a href="#">Patient Module</a>
<b>Study</b>	General Study	ALWAYS		<a href="#">General Study</a>
<b>Series</b>	General Series	ALWAYS		<a href="#">General Series</a>
	Whole Slide Microscopy Series	ALWAYS		<a href="#">Whole Slide Microscopy Series</a>
<b>Frame Of Reference</b>	Frame of Reference	ALWAYS		<a href="#">Frame of Reference</a>
<b>Equipment</b>	General Equipment	ALWAYS		<a href="#">General Equipment</a>
	Enhanced General Equipment	ALWAYS		<a href="#">Enhanced General Equipment</a>
<b>Acquisition</b>	General Acquisition	ALWAYS		<a href="#">General Acquisition</a>
<b>Multi-Resolution Pyramid</b>	Multi-Resolution Pyramid	CONDITIONAL	Present only if Image Type Value-3 is VOLUME.	<a href="#">Multi-Resolution Pyramid</a>
<b>Image</b>	General Image	ALWAYS		<a href="#">General Image</a>
	Microscope Slide Layer Tile Organization	ALWAYS		<a href="#">Microscope Slide Layer Tile Organization</a>
	Image Pixel	ALWAYS		<a href="#">Image Pixel</a>
	Acquisition Context	ALWAYS		<a href="#">Acquisition Context</a>
	Multi-frame Functional Groups	ALWAYS		<a href="#">Multi-frame Functional Groups</a>
	Multi-frame Dimension	ALWAYS		<a href="#">Multi-frame Dimension</a>
	Specimen	ALWAYS		<a href="#">Specimen</a>
	Whole Slide Microscopy Image	ALWAYS		<a href="#">Whole Slide Microscopy Image</a>
	Optical Path	ALWAYS		<a href="#">Optical Path</a>
	Slide Label	ALWAYS		<a href="#">Slide Label</a>
	SOP Common	ALWAYS		<a href="#">SOP Common</a>
	Common Instance Reference	CONDITIONAL	Present only if Image Type Value-1 is DERIVED and Value-3 is VOLUME	<a href="#">Common Instance Reference</a>

**A.2.1 VL Whole Slide Microscopy Image IOD - Specific Modules**

The following tables list Modules and Attributes specific for VL Whole Slide Microscopy Image IOD

**Table A-3: Patient Module**

Attribute Name	Tag	Source	Presence of Attribute	Presence of Value	Value	Conditions	Comments
Patient's Name	0010,0010	EMPTY	ALWAYS	EMPTY			-
Patient ID	0010,0020	EMPTY	ALWAYS	EMPTY			-
Patient's Birth Date	0010,0030	EMPTY	ALWAYS	EMPTY			-
Patient's Sex	0010,0040	EMPTY	ALWAYS	EMPTY			-

**Table A-4: General Study Module**

Attribute Name	Tag	Source	Presence of Attribute	Presence of Value	Value	Conditions	Comments
Study Date	0008,0020	GENERATED	ALWAYS	ALWAYS			-
Study Time	0008,0030	GENERATED	ALWAYS	ALWAYS			-
Accession Number	0008,0050	EMPTY	ALWAYS	EMPTY			-
Referring Physician's Name	0008,0090	EMPTY	ALWAYS	EMPTY			-
Study Instance UID	0020,000D	GENERATED	ALWAYS	ALWAYS			-
Study ID	0020,0010	EMPTY	ALWAYS	EMPTY			-

**Table A-5: General Series Module**

Attribute Name	Tag	Source	Presence of Attribute	Presence of Value	Value	Conditions	Comments
Modality	0008,0060	FIXED	ALWAYS	ALWAYS	SM		-
Series Instance UID	0020,000E	GENERATED	ALWAYS	ALWAYS			-
Series Number	0020,0011	FIXED	ALWAYS	ALWAYS	1		-

**Table A-6: Whole Slide Microscopy Series Module**

Attribute Name	Tag	Source	Presence of Attribute	Presence of Value	Value	Conditions	Comments
Modality	0008,0060	FIXED	ALWAYS	ALWAYS	SM		-

**Table A-7: Frame of Reference Module**

Attribute Name	Tag	Source	Presence of Attribute	Presence of Value	Value	Conditions	Comments
Frame of Reference UID	0020,0052	GENERATED	ALWAYS	ALWAYS			-
Position Reference Indicator	0020,1040	FIXED	ALWAYS	ALWAYS	SLIDE_CORNER		-

**Table A-8: General Equipment Module**

Attribute Name	Tag	Source	Presence of Attribute	Presence of Value	Value	Conditions	Comments
Manufacturer	0008,0070	GENERATED	ALWAYS	ALWAYS			-
Manufacturer's Model Name	0008,1090	GENERATED	ALWAYS	ALWAYS			-
Device Serial Number	0018,1000	GENERATED	ALWAYS	ALWAYS			-
Software Versions	0018,1020	GENERATED	ALWAYS	ALWAYS			-

**Table A-9: Enhanced General Equipment Module**

Attribute Name	Tag	Source	Presence of Attribute	Presence of Value	Value	Conditions	Comments
Manufacturer	0008,0070	GENERATED	ALWAYS	ALWAYS			-
Manufacturer's Model Name	0008,1090	GENERATED	ALWAYS	ALWAYS			-
Device Serial Number	0018,1000	GENERATED	ALWAYS	ALWAYS			-
Software Versions	0018,1020	GENERATED	ALWAYS	ALWAYS			-

**Table A-10: General Acquisition Module**

Attribute Name	Tag	Source	Presence of Attribute	Presence of Value	Value	Conditions	Comments
Acquisition DateTime	0008,002A	GENERATED	ALWAYS	ALWAYS			Format: YYYYMMDDHHM MSS.FFFFFFF&ZZX X

**Table A-11: Multi-Resolution Pyramid Module**

Attribute Name	Tag	Source	Presence of Attribute	Presence of Value	Value	Conditions	Comments
Pyramid UID	0008,0019	GENERATED	ALWAYS	ALWAYS			-

**Table A-12: General Image Module**

Attribute Name	Tag	Source	Presence of Attribute	Presence of Value	Value	Conditions	Comments
Instance Number	0020,0013	GENERATED	ALWAYS	ALWAYS			Range: 1-(n+2) value 1 is used for the base layer, 2 for next layer, etc. Value n+1 is for the overview image and n+2 for the label image, where n is the number of images in the pyramid for a scanned slide. All images in the range 1-(n+2) shall be present.
Content Date	0008,0023	GENERATED	ALWAYS	ALWAYS			Format: YYYYMMDD
Content Time	0008,0033	GENERATED	ALWAYS	ALWAYS			Format: HHMMSS
Image Type	0008,0008	GENERATED	ALWAYS	ALWAYS			See Table A-30: Image type - Values and Code Sets
Burned In Annotation	0028,0301	FIXED	ALWAYS	ALWAYS	NO		-

Lossy Image Compression	0028,2110	FIXED	ALWAYS	ALWAYS	01		-
Lossy Image Compression Ratio	0028,2112	GENERATED	ALWAYS	ALWAYS			-
Lossy Image Compression Method	0028,2114	GENERATED	ALWAYS	ALWAYS			ISO_10918_1 for Image Type Value-3 is LABEL or OVERVIEW.  ISO_10918_1 or ISO_18181_1 for Image Type Value-3 is VOLUME.

Table A-13: Microscope Slide Layer Tile Organization Module

Attribute Name	Tag	Source	Presence of Attribute	Presence of Value	Value	Conditions	Comments
Total Pixel Matrix Columns	0048,0006	GENERATED	ALWAYS	ALWAYS			-
Total Pixel Matrix Rows	0048,0007	GENERATED	ALWAYS	ALWAYS			-
Total Pixel Matrix Focal Plane	0048,0303	FIXED	ALWAYS	ALWAYS	1		-
Total Pixel Matrix Origin Sequence	0048,0008	GENERATED	ALWAYS	ALWAYS			-
>X Offset in Slide Coordinate System	0040,072A	GENERATED	ALWAYS	ALWAYS			-
>Y Offset in Slide Coordinate System	0040,073A	GENERATED	ALWAYS	ALWAYS			-
Image Orientation (Slide)	0048,0102	GENERATED	ALWAYS	ALWAYS			-
Tiles Overlap	0048,0304	FIXED	ALWAYS	ALWAYS	NONE		-

Table A-14: Image Pixel Module

Attribute Name	Tag	Source	Presence of Attribute	Presence of Value	Value	Conditions	Comments
Samples per Pixel	0028,0002	FIXED	ALWAYS	ALWAYS	3		-

Photometric Interpretation	0028,0004	GENERATED	ALWAYS	ALWAYS			See Table A-29 Photometric Interpretation - Values and Code Sets
Planar Configuration	0028,0006	FIXED	ALWAYS	ALWAYS	0		-
Rows	0028,0010	GENERATED	ALWAYS	ALWAYS			-
Columns	0028,0011	GENERATED	ALWAYS	ALWAYS			-
Bits Allocated	0028,0100	GENERATED	ALWAYS	ALWAYS			-
Bits Stored	0028,0101	GENERATED	ALWAYS	ALWAYS			-
High Bit	0028,0102	GENERATED	ALWAYS	ALWAYS			-
Pixel Representation	0028,0103	FIXED	ALWAYS	ALWAYS	0		-
Pixel Data	7FE0,0010	GENERATED	ALWAYS	ALWAYS			-

Table A-15: Acquisition context Module

Attribute Name	Tag	Source	Presence of Attribute	Presence of Value	Value	Conditions	Comments
Acquisition Context Sequence	0040,0555	EMPTY	ALWAYS	EMPTY			-
Acquisition Context Description	0040,0556	GENERATED	ALWAYS	ALWAYS			-

Table A-16: Multi-Frame Functional Groups Module

Attribute Name	Tag	Source	Presence of Attribute	Presence of Value	Value	Conditions	Comments
Content Date	0008,0023	GENERATED	ALWAYS	ALWAYS			Format: YYYYMMDD
Content Time	0008,0033	GENERATED	ALWAYS	ALWAYS			Format: HHMMSS
Instance Number	0020,0013	GENERATED	ALWAYS	ALWAYS			-
Number of Frames	0028,0008	GENERATED	ALWAYS	ALWAYS			-
Shared Functional Groups Sequence	5200,9229	GENERATED	ALWAYS	ALWAYS			-

>Pixel Measures Sequence	0028,9110	GENERATED	ALWAYS	ALWAYS			See Table A-24: Pixel Measures Functional Group Macro
>Derivation Image Sequence	0008,9124	GENERATED	CONDITIONAL	ALWAYS		Present only if Image Type Value 1 is Derived and Value-3 is VOLUME.	See Table A-25: Derivation Image Macro
>Whole Slide Microscopy Image Frame Type Sequence	0040,0710	GENERATED	ALWAYS	ALWAYS			See Table A-26: Whole Slide Microscopy Image Frame Type Macro

Table A-17: Multi-Frame Dimension Module

Attribute Name	Tag	Source	Presence of Attribute	Presence of Value	Value	Conditions	Comments
Dimension Organization Sequence	0020,9221	GENERATED	ALWAYS	ALWAYS			-
>Dimension Organization UID	0020,9164	GENERATED	ALWAYS	ALWAYS			-
Dimension Organization Type	0020,9311	FIXED	ALWAYS	ALWAYS	TILED_FULL		-

Table A-18: Specimen Module

Attribute Name	Tag	Source	Presence of Attribute	Presence of Value	Value	Conditions	Comments
Container Identifier	0040,0512	GENERATED	ALWAYS	ALWAYS			-
Issuer of the Container Identifier Sequence	0040,0513	EMPTY	ALWAYS	EMPTY			-
Container Type Code Sequence	0040,0518	GENERATED	ALWAYS	ALWAYS			-
>Code Value	0008,0100	FIXED	ALWAYS	ALWAYS	433466003		-
>Coding Scheme Designator	0008,0102	FIXED	ALWAYS	ALWAYS	SCT		-
>Code Meaning	0008,0104	FIXED	ALWAYS	ALWAYS	Microscope slide		-

Specimen Description Sequence	0040,0560	GENERATED	ALWAYS	ALWAYS			-
>Specimen Identifier	0040,0551	GENERATED	ALWAYS	ALWAYS			-
>Specimen UID	0040,0554	GENERATED	ALWAYS	ALWAYS			-
>Specimen Preparation Sequence	0040,0610	EMPTY	ALWAYS	EMPTY			-
>Issuer of the Specimen Identifier Sequence	0040,0562	EMPTY	ALWAYS	EMPTY			-

**Table A-19: Whole Slide Microscopy Image Module**

Attribute Name	Tag	Source	Presence of Attribute	Presence of Value	Value	Conditions	Comments
Image Type	0008,0008	GENERATED	ALWAYS	ALWAYS			See Table A-27: Image type - Values and Code Sets
Acquisition DateTime	0008,002A	GENERATED	ALWAYS	ALWAYS			Format: YYYYMMDDHHM MSS.FFFFFFF&ZZX X
Volumetric Properties	0008,9206	FIXED	ALWAYS	ALWAYS	VOLUME		-
Samples Per Pixel	0028,0002	FIXED	ALWAYS	ALWAYS	3		-
Photometric Interpretation	0028,0004	GENERATED	ALWAYS	ALWAYS			See Table A-29 Photometric Interpretation - Values and Code Sets
Planar Configuration	0028,0006	FIXED	ALWAYS	ALWAYS	0		-
Number of Frames	0028,0008	GENERATED	ALWAYS	ALWAYS			-
Bits Allocated	0028,0100	GENERATED	ALWAYS	ALWAYS			-
Bits Stored	0028,0101	GENERATED	ALWAYS	ALWAYS			-
High Bit	0028,0102	GENERATED	ALWAYS	ALWAYS			-

Pixel Representation	0028,0103	FIXED	ALWAYS	ALWAYS	0		-
Burned In Annotation	0028,0301	FIXED	ALWAYS	ALWAYS	NO		-
Lossy Image Compression	0028,2110	FIXED	ALWAYS	ALWAYS	01		-
Lossy Image Compression Ratio	0028,2112	GENERATED	ALWAYS	ALWAYS			-
Lossy Image Compression Method	0028,2114	GENERATED	ALWAYS	ALWAYS			ISO_10918_1 for Image Type Value-3 is LABEL or OVERVIEW.  ISO_10918_1 or ISO_18181_1 for Image Type Value-3 is VOLUME.
Imaged Volume Width	0048,0001	GENERATED	ALWAYS	ALWAYS			-
Imaged Volume Height	0048,0002	GENERATED	ALWAYS	ALWAYS			-
Imaged Volume Depth	0048,0003	GENERATED	CONDITIONAL	ALWAYS		Present only if Image Type Value-3 is VOLUME.	-
Specimen Label in Image	0048,0010	GENERATED	ALWAYS	ALWAYS			YES, if Image Type Value-3 is LABEL, else NO.
Focus Method	0048,0011	FIXED	ALWAYS	ALWAYS	AUTO		-
Extended Depth of Field	0048,0012	FIXED	ALWAYS	ALWAYS	NO		-

Table A-20: Optical Path Module

Attribute Name	Tag	Source	Presence of Attribute	Presence of Value	Value	Conditions	Comments
Optical Path Sequence	0048,0105	GENERATED	ALWAYS	ALWAYS			-
>Illumination Type Code Sequence	0022,0016	GENERATED	ALWAYS	ALWAYS			See Table A-28: Illumination type Code Sequence -

							Values and Code Sets
>>Code Value	0008,0100	GENERATED	ALWAYS	ALWAYS			-
>>Coding Scheme Designator	0008,0102	GENERATED	ALWAYS	ALWAYS			-
>>Code Meaning	0008,0104	GENERATED	ALWAYS	ALWAYS			-
>ICC Profile	0028,2000	GENERATED	ALWAYS	ALWAYS			-
>Color Space	0028,2002	FIXED	CONDITIONAL	ALWAYS	SRGB	Present only if Image Type Value-3 is OVERVIEW or LABEL.	-
>Optical Path Identifier	0048,0106	GENERATED	ALWAYS	ALWAYS			See Table A-28: Illumination type Code Sequence - Values and Code Sets
> Illumination Color Code Sequence	0048,0108	GENERATED	ALWAYS	ALWAYS			-
>>Code Value	0008,0100	FIXED	ALWAYS	ALWAYS	414298005		-
>>Coding Scheme Designator	0008,0102	FIXED	ALWAYS	ALWAYS	SCT		-
>>Code Meaning	0008,0104	FIXED	ALWAYS	ALWAYS	Full Spectrum		-
Number of Optical Paths	0048,0302	FIXED	ALWAYS	ALWAYS	1		-

Table A-21: Slide Label Module

Attribute Name	Tag	Source	Presence of Attribute	Presence of Value	Value	Conditions	Comments
Label Text	2200,0002	EMPTY	ALWAYS	EMPTY			-
Barcode Value	2200,0005	GENERATED	ALWAYS	ALWAYS			Value is empty if no barcode is detected or selected.

**Table A-22: SOP Common Module**

Attribute Name	Tag	Source	Presence of Attribute	Presence of Value	Value	Conditions	Comments
SOP Class UID	0008,0016	FIXED	ALWAYS	ALWAYS	1.2.840.10008.5.1.4.1.1.77.1.6		-
SOP Instance UID	0008,0018	GENERATED	ALWAYS	ALWAYS			-
Specific Character Set	0008,0005	FIXED	ALWAYS	ALWAYS	ISO_IR 192		-
Timezone Offset From UTC	0008,0201	GENERATED	ALWAYS	ALWAYS			-

**Table A-23: Common Instance Reference Module**

Attribute Name	Tag	Source	Presence of Attribute	Presence of Value	Value	Conditions	Comments
Referenced Series Sequence	0008,1115	GENERATED	ALWAYS	ALWAYS			-
>Referenced Instance Sequence	0008,114A	GENERATED	ALWAYS	ALWAYS			-
>>Referenced SOP Class UID	0008,1150	GENERATED	ALWAYS	ALWAYS			-
>>Referenced SOP Instance UID	0008,1155	GENERATED	ALWAYS	ALWAYS			-
>Series Instance UID	0020,000E	GENERATED	ALWAYS	ALWAYS			-

**A.2.2 VL Whole Slide Microscopy Image IOD - Functional Group Macros**

The tables below list functional group macros and Attributes for VL Whole Slide Microscopy Image IOD:

**Table A-24: Pixel Measures Functional Group Macro**

Attribute Name	Tag	Source	Presence of Attribute	Presence of Value	Value	Conditions	Comments
Pixel Measures Sequence	0028,9110	GENERATED	ALWAYS	ALWAYS			-
>Slice Thickness	0018,0050	GENERATED	CONDITIONAL	ALWAYS		Present only if Image Type	-

						Value-3 is VOLUME.	
>Spacing Between Slices	0018,0088	FIXED	ALWAYS	ALWAYS	0		-
>Pixel Spacing	0028,0030	GENERATED	ALWAYS	ALWAYS			-

Table A-25: Derivation Image Functional Group Macro

Attribute Name	Tag	Source	Presence of Attribute	Presence of Value	Value	Conditions	Comments
Derivation Image Sequence	0008,9124	GENERATED	ALWAYS	ALWAYS			-
>Derivation Description	0008,2111	GENERATED	ALWAYS	ALWAYS			-
>Derivation Code Sequence	0008,9215	GENERATED	ALWAYS	ALWAYS			-
>>Code Value	0008,0100	GENERATED	ALWAYS	ALWAYS			-
>>Coding Scheme Designator	0008,0102	GENERATED	ALWAYS	ALWAYS			-
>>Code Meaning	0008,0104	GENERATED	ALWAYS	ALWAYS			-
>Source Image Sequence	0008,2112	GENERATED	ALWAYS	ALWAYS			-
>>Referenced SOP Class UID	0008,1150	GENERATED	ALWAYS	ALWAYS			-
>>Referenced SOP Instance UID	0008,1155	GENERATED	ALWAYS	ALWAYS			-
>>Purpose of Reference Code Sequence	0040,A170	GENERATED	ALWAYS	ALWAYS			-
>>>Code Value	0008,0100	GENERATED	ALWAYS	ALWAYS			-
>>>Coding Scheme Designator	0008,0102	GENERATED	ALWAYS	ALWAYS			-
>>>Code Meaning	0008,0104	GENERATED	ALWAYS	ALWAYS			-

Table A-26: Whole Slide Microscopy Image Frame Type Macro

Attribute Name	Tag	Source	Presence of Attribute	Presence of Value	Value	Conditions	Comments
>Whole Slide Microscopy Image Frame Type Sequence	0040,0710	GENERATED	ALWAYS	ALWAYS			-

>>Frame Type	0008,9007	GENERATED	ALWAYS	ALWAYS		Same as Image type	See Table A-27: Image type - Values and Code Sets
--------------	-----------	-----------	--------	--------	--	--------------------	---

**A.2.3 VL Whole Slide Microscopy Image IOD - Private Modules -N/A**

Not Applicable, not supported by product.

**A.2.4 VL Whole Slide Microscopy Image IOD - Coded Values**

The table below lists Coded Values referenced from the "Value" column of the tables above for VL Whole Slide Microscopy Image IOD:

**Table A-27: Image type - Values and Code Sets**

Attribute Name	Tag	Value 1	Value 2	Value 3	Value 4	Condition	Comments
Image Type	0008,0008	ORIGINAL	PRIMARY	VOLUME	NONE		Full resolution scanned image
		DERIVED	PRIMARY	VOLUME	RESAMPLED		Decreased resolution zoomed image
		ORIGINAL	PRIMARY	LABEL	NONE		Slide Label Image
		ORIGINAL	PRIMARY	OVERVIEW	NONE		Overview Image

**Table A-28: Illumination type Code Sequence - Values and Code Sets**

Attribute Name	Tag	Value/Code	Condition	Comments
Illumination type Code Sequence	0022,0016	(111744, DCM, Brightfield illumination)	0048,0106 = VOLUME	CID 8123 Microscopy Illumination Method
		(111741, DCM, Transmission illumination)	0048,0106 = OVERVIEW	
		(111742, DCM, Reflection illumination)	0048,0106 = LABEL	
Optical Path Identifier	0048,0106	VOLUME	Image Type Value-3 is VOLUME	-

		OVERVIEW	Image Type Value-3 is OVERVIEW	-
		LABEL	Image Type Value-3 is LABEL	-

**Table A-29: Photometric Interpretation - Values and Code Sets**

Attribute Name	Tag	Value/Code	Condition	Comments
Photometric Interpretation	0028,0004	YBR_FULL_422	Transfer Syntax is JPEG Baseline (Process 1)	-
		XYB	Transfer Syntax is JPEG XL	-

**B. Structured Report Content Encoding – N/A**

Not applicable, not supported by product.

**C. Security Details**

This section provides additional details about security features that are formally described in Section 8.

**C.1 External Network Requirement Details**

**C.1.1 Basic Time Synchronization**

If no NTP Servers are available, time can be configured manually.

**C.1.2 Basic Network Address Management**

DHCP client discovers a DHCP server using a broadcast-based discovery process.

**C.2 DICOM Security Profile Details**

**C.2.1 Online Electronic Storage Secure Use – N/A**

Not applicable. Product does not support online electronic storage secure use.

**C.2.2 Audit Trail Messages -N/A**

Not applicable. Product does not support audit trail message transmission profile.

**C.2.3 Audit Trail Message Transmission Profile - SYSLOG – TLS -N/A**

Not applicable. Product does not support audit trail message transmission profile.

**C.2.4 Audit Trail Message Transmission Profile - SYSLOG – UDP -N/A**

Not applicable. Product does not support audit trail message transmission profile.

**C.2.5 Secure Transport Connection Details**

Table C.2.5 1 lists the secure transport connection profiles and cipher suites supported for TLS v1.3:

**Table C.2.5 1: Secure Transport Connection Profiles and Cipher Suites**

Profile	Cipher Suite	Default Preference Order (from 1=preferred to n=less preferred)
BCP 195 RFC 8996, 9325 TLS Secure Transport Connection Profile	TLS_AES_256_GCM_SHA384	1
	TLS_AES_128_GCM_SHA256	2
	TLS_AES_128_CCM_SHA256	3
Modified BCP 195 RFC 8996, 9325 TLS Secure Transport Connection Profile	TLS_AES_256_GCM_SHA384	1
	TLS_AES_128_GCM_SHA256	2
	TLS_AES_128_CCM_SHA256	3

Table C.2.5 2 lists the secure transport connection profiles and key exchange algorithms supported for TLS v1.3:

**Table C.2.5 2: Secure Transport Connection Profiles and TLS v1.3 Key Exchange Algorithms**

Profile	Key Exchange Algorithms	Default Preference Order (from 1=preferred to n=less preferred)
BCP 195 RFC 8996, 9325 TLS Secure Transport Connection Profile	ECDHE	1
	DHE	2
Modified BCP 195 RFC 8996, 9325 TLS Secure Transport Connection Profile	ECDHE	1
	DHE	2

Table C.2.5 3 lists the secure transport connection profiles and signature algorithms supported for TLS v1.3:

**Table C.2.5 3: Secure Transport Connection Profiles and TLS v1.3 Signature Algorithms**

Profile	Signature Algorithms	Default Preference Order (from 1=preferred to n=less preferred)
BCP 195 RFC 8996, 9325 TLS Secure Transport Connection Profile	ECDSA	1
	RSA PSS	2
	RSA PKCS#1 v1.5	3
Modified BCP 195 RFC 8996, 9325 TLS Secure Transport Connection Profile	ECDSA	1
	RSA PSS	2
	RSA PKCS#1 v1.5	3

Table C-4 lists the secure transport connection profiles and cipher suites supported for TLS v1.2:

**Table C-4: Secure Transport Connection Profiles and TLS v1.2 Cipher Suites**

Profile	Cipher Suite	Default Preference Order (from 1=preferred to n=less preferred)
BCP 195 RFC 8996, 9325 TLS Secure Transport Connection Profile	TLS_ECDHE_ECDSA_WITH_AES_256_GCM_SHA384	1
	TLS_ECDHE_RSA_WITH_AES_256_GCM_SHA384	2
	TLS_ECDHE_ECDSA_WITH_AES_256_CCM	3
	TLS_ECDHE_ECDSA_WITH_AES_128_GCM_SHA256	4
	TLS_ECDHE_RSA_WITH_AES_128_GCM_SHA256	5
	TLS_ECDHE_ECDSA_WITH_AES_128_CCM	6
	TLS_DHE_RSA_WITH_AES_256_GCM_SHA384	7
	TLS_DHE_RSA_WITH_AES_256_CCM	8
	TLS_DHE_RSA_WITH_AES_128_GCM_SHA256	9
	TLS_DHE_RSA_WITH_AES_128_CCM	10
Modified BCP 195 RFC 8996, 9325 TLS Secure Transport Connection Profile	TLS_ECDHE_ECDSA_WITH_AES_256_GCM_SHA384	1
	TLS_ECDHE_RSA_WITH_AES_256_GCM_SHA384	2
	TLS_ECDHE_ECDSA_WITH_AES_256_CCM	3
	TLS_ECDHE_ECDSA_WITH_AES_128_GCM_SHA256	4
	TLS_ECDHE_RSA_WITH_AES_128_GCM_SHA256	5

	TLS_ECDHE_ECDSA_WITH_AES_128_CCM	6
	TLS_DHE_RSA_WITH_AES_256_GCM_SHA384	7
	TLS_DHE_RSA_WITH_AES_256_CCM	8
	TLS_DHE_RSA_WITH_AES_128_GCM_SHA256	9
	TLS_DHE_RSA_WITH_AES_128_CCM	10

Table C-5 describes the configurable parameters and behaviors supported by this product for the Secure Transport Connection:

**Table C-5: Secure Transport Connection Configuration**

Local Secure Transport Connection Configuration			
Parameter/Behavior	Configurable	Default Value	Comments
<b>Common Secure Transport Connection parameters</b>			
Port	See Section 6 Configuration		
Client certificate	See Section 6 Configuration		
<b>BCP 195 RFC 8996 TLS Secure Transport Connection</b>			
Security Level	Yes	BCP-195	
<b>Modified BCP 195 RFC 8996, 9325 TLS Secure Transport Connection Parameters</b>			
Security Level	Yes	Modified-BCP-195	

**C.2.6 Attribute Confidentiality Details -N/A**

Not applicable, not supported by product.

**C.2.7 Digital Signature Details – N/A**

Not applicable, not supported by product.

**C.2.8 Additional DICOM Security Profile Details – N/A**

Not applicable, not supported by product.

**D. Mapping of Attributes -N/A**

Not applicable, not supported by product.

**E. Code Set Usage**

Philips Pathology Scanner SGI uses SNOMED CT codes.

*- This page is left intentionally empty -*

**Issued by:**

Philips Medical Systems Nederland B.V.

Veenpluis 6

5684 PC Best

The Netherlands

Note that the address is also known as “Veenpluis 4-6”, which refers to the same physical location.

Internet: <https://www.usa.philips.com/healthcare/support/interoperability-standards>

